



# FIBER FORCE



## Instruction Manual

Insulation blowing machine

*Original Language – English*

Intec —9251 Bruin BLVD, Frederick, CO 80504 USA

**T:** 303-833-6644

**Web:** [www.inteccorp.com](http://www.inteccorp.com)

**Email:** [info@inteccorp.com](mailto:info@inteccorp.com)

*Rev Date: 20211212*

## Introduction

Since 1977, both professional contractors and do-it-yourself equipment users have looked to Intec as the industry leader in the design and manufacture of innovative portable insulation blowing equipment. Now those same individuals are profiting thru the use of our high powered vacuums that are Engineered for High Productivity and Built-to-Last for High Value Generation. We take pride in making your job as easy and profitable as possible.

The right system for your needs: Intec strives to provide you with the best combination of portability, functionality, and installation versatility to surpass your desired success. From lightweight polyethylene units with removable hoppers, to larger units with increased production rates and installation versatility, all of our durable systems are made to maximize your profit generating potential.

Best-in-class Customer Service: Total ease of use extends beyond your initial purchase of an Intec system to your evolving needs thru the entire lifecycle. Both before and after the sale service is important to keep you running at peak operating capabilities. Intec's technical team provides installation assistance in addition to maintenance suggestions and trouble-shooting support. In addition to blowing machines, Intec produces a range of accessories that will increase your productivity when dense packing, damp spraying, and installing net and blow.

Thank you for partnering with Intec. We appreciate the confidence and trust you have placed in us, and wish you many profit-generating opportunities!



A handwritten signature in black ink, appearing to read "Ray", written in a cursive style.

Ray Lavallee  
President, Intec

## Table of Contents







<b>SYMBOLS.....</b>	<b>3</b>
<b>SAFETY FIRST .....</b>	<b>3</b>
<b>HOW THE SYSTEM WORKS.....</b>	<b>4</b>
<b>SYSTEM SET-UP: .....</b>	<b>6</b>
<b>SYSTEM OPERATION:.....</b>	<b>7</b>
<b>MAINTENANCE .....</b>	<b>9</b>
<b>SPECIFICATIONS .....</b>	<b>12</b>
<b>ELECTRICAL DRAWING – ELECTRICAL PANEL.....</b>	<b>13</b>
<b>MAKING A CLAIM FOR DAMAGE OR LOSS .....</b>	<b>15</b>
<b>WARRANTY .....</b>	<b>16</b>

## Symbols





SYMBOL	SYMBOL	MEANING
	Danger	Indicates an imminently hazardous situation, which, if not avoided, will result in death or serious injury.
	Warning	Indicates a potentially hazardous situation, which, if not avoided, could result in death or serious injury.
	Caution	Indicates a potentially hazardous situation, which, if not avoided, may result in minor or moderate injury.

## Safety First



-  Disconnect all power cords prior to working on the equipment. Failure to do so could result in injury or death.
-  Never operate equipment with guards removed.
-  Never operate equipment with hopper removed.
-  Never operate equipment while standing in water as electrical shock may result.
-  Never put hands into hopper or machine outlet while machine is operating.
-  Always use grounded extension cords when operating equipment.



-  When working with insulation, always wear a long sleeve shirt, gloves and a hat. Wear goggles or safety glasses for eye protection. Wear a mask for respiratory protection.
-  Keep tools and foreign objects out of the hopper.
-  Never leave the machine unattended during operation. Disconnect all power to the machine when unattended.
-  Never operate the equipment with the access panels off, possible injury may occur.
-  Prior to use, inspect power cord and remote cord prior to ensure no damage exists.



## How the System Works

**OVERVIEW:** Cellulose or Fiberglass insulation is loaded into the hopper. The insulation goes through the agitator. The agitator breaks-up and conditions the insulation for proper density while also sweeping the insulation into the airlock. The airlock transports the insulation into the airstream created by the blower system. Insulation is discharged from the airlock, through the machine outlet, and into the hose. The insulation is further conditioned as it travels through the hose.

An introduction to key components of the system follows:

**Hopper:** Contains the insulation being fed into the agitators. The hopper for the Fiber Force is available in both the standard size and Tall

**Base:** The Base contains all electrical and mechanical components for the FiberForce.

**Magnetic Safety Interlock:** The Magnetic Safety Interlock only allows the unit to function when the hopper is on the base. *Note: The hopper is directional; the system will only work when the hopper is installed as depicted in picture with hopper opening above operator control panel & inlet air filter.*

**Loading Platform:** Used to support the insulation as it is being loaded into the machine.

**Hopper Latches:** Each of the four fasten the hopper to base for operation.

**Operator Control Panel:** Provides Main Circuit Breaker, Agitator Circuit Breaker, control panel ON & OFF buttons, Hour Meter, and instructions.

**Inlet Air Filter:** Ensures clean air enters the system for cooling and to provide inlet air to blower. Please clean at the start of each job to ensure maximum airflow is available to the blower.



Figure 1

**BASE DETAILS** (see Figure 2)

**Agitators:** The Agitators condition the fibrous insulation. The configuration enables high production rates and appropriate insulation conditioning. The Agitators also transport the insulation into the airlock.

**Agitator Basin:** The lower section of the base between the agitators and airlock entrance.

**Slide Gate (optional):** The Slide Gate is between the agitators and the airlock. The Slide Gate allows insulation to fall into the airlock at various rates depending on the user's preference: open slide gate more fully for typical insulation conditioning (& quickest production); open slide gate less fully for additional insulation conditioning. The Slide Gate is opened fully during typical attic operation, thus for many models with intent to insulate attics a slide gate is not provided.

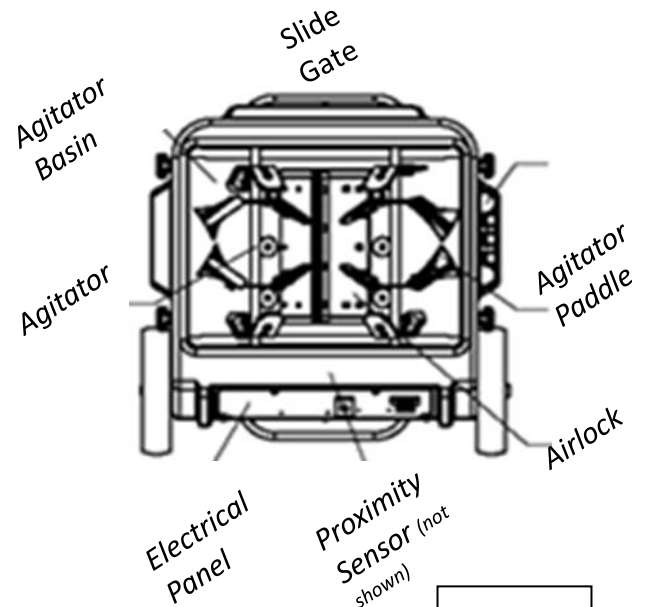

Figure 2

**Agitator Paddle:** Each are unique and positioned to provide ideal insulation conditioning.

**Airlock:** The Airlock transfers the insulation from the agitation system into the airstream without coming into contact with the blower. Insulation is discharged from the airlock into the hose.

**Proximity Sensor:** Combines with the Magnetic Safety Interlock to ensure safe operation of unit only when hopper is placed appropriately on base.

**Electrical Panel:** Provides for operator control on the outside, and also is an access panel providing access to the majority of FiberForce's electronics.

**Blowing Hose** (see Figure 3): The blowing hose further conditions the insulation as it transports the product from the airlock to the installation location. Note that you will want to use a minimum of 100 feet of hose to ensure proper material conditioning. Figure 3 provides an overview of the 2-1/2" hose provided with the system. Note the section with two connectors (section 1 in Figure 3) is connected to the FiberForce blowing machine; the section with the wireless remote transmitter (section 2 in Figure 3) is connected to the first piece.

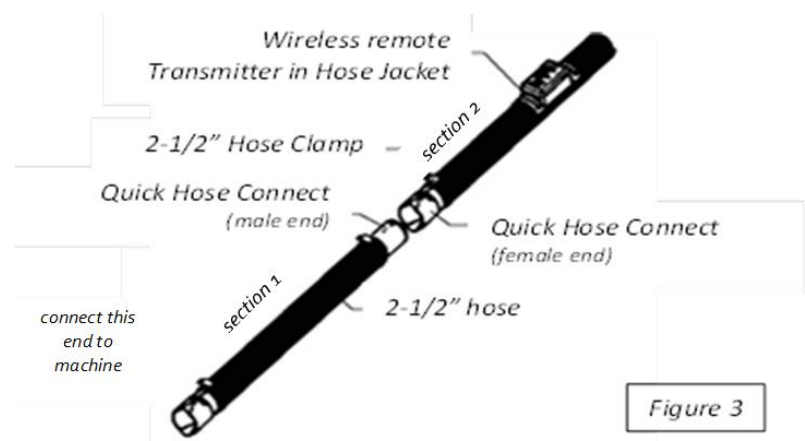

Figure 3

T: 303-833-6644

www.inteccorp.com

## Set up and Operation



### System Set-Up:

Set system on a dry, level surface.

1. Obtain appropriate protective equipment.
2. Make sure there is nothing left in the hopper or base from transporting. Unexpected objects in the hopper can cause damage to the agitator or airlock upon start-up.
3. Ensure your system is located on a stable flat surface to maintain even loading and blowing. Note: Please ensure that the hopper opening is above the Fiber Force's filter section as this is the appropriate orientation for the hopper to allow the system to operate. The hopper's key slot will match the bases 'key' as intended with this orientation; allowing the green and red lights to come on and the system to be operational.
4. Using the supplied 12 gauge heavy duty power cord, connect the female twist lock to the machine's power receptacle, and the male end to a 115V - 15amp circuit (connecting to a 20amp circuit is fine, yet not required).
5. Attach hose to machine outlet by sliding the female end of the quick hose connect over the machine's male outlet until the round button clicks into the hole.



Machine's power receptacle



6. Open slide gate & place pin in desired opening.  
*Note: The slide gate is optional and not required in all machines. If your system does not have a slide gate, proceed to System Operation.*



## System Operation:

### 1. Energize System

- a. Place the main circuit breaker in the ON position.
- b. The START button and the STOP button should be illuminated, green & red, indicating the system is ready to start.

*Note: Ensure that the agitator circuit breaker is not tripped. It should be pushed in as far as possible.*



### 2. System Control – From either Operator Panel or Wireless Remote

#### a. Operator Panel

- i. Press the green *START* button to turn the system on.

The blower will start. After approximately 3-5 seconds the agitator will also start.

*Note: This system is designed for the blower motor to start first as this provides an audible (i.e. sound warning) that the system's agitators are about to start.*

- ii. Press the red *STOP* button to turn the system off. Both the agitator and blower will stop.

#### b. Wireless Remote

- i. Press the green button to turn the system on.

The blower will start. After approximately 3-5 seconds the agitator will also start.

*Note: This system is designed for the blower motor to start first as this provides an audible (i.e. sound warning) that the system's agitators are about to start.*

- ii. Press the red button to turn the system off. Both the agitator and blower will stop.





### 3. Load Insulation

**Cellulose:** Place full bag on loading platform. Remove packaging and place full bale of cellulose into hopper. Note: when using the small hopper configuration, you will need to place a fraction of the bag into the hopper to allow product to fit into hopper entrance.



#### Fiberglass:



*Cut bag in half*



*Bend bag to break*

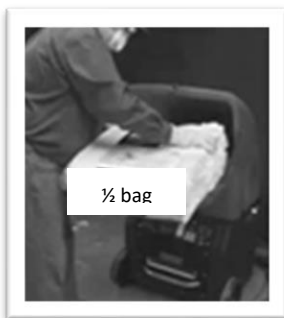

*Place half bag on hopper with open end facing a side. Then cut the plastic side facing the hopper and allow the product to expand into the hopper. Caution – do not force product into the hopper. The natural expansion of product into the hopper is all that is required to place product into hopper.*

## Maintenance

Preventative maintenance will provide for many years of trouble-free use.

### Cleaning

Clean the interior and exterior of the machine weekly by wiping with a rag and/or blowing with compressed air; this will help maintain the longevity of the mechanical components in addition to the system's finish. The machine has been designed to work in a dusty environment. However, without periodic cleaning and maintenance, the performance of the machine will decline potentially leading to failure.

### Power Cord

Your power cord is subject to considerable wear and tear during normal operation. Inspect all cords prior to use to ensure safe operation. If any damage is observed, be sure to repair or replace before operating the machine to avoid personal injury. Note: Do not pull on power cords while plugged into machine or wall as damage may occur.

### Airlock and Seals

The airlock assembly is one the most important items to keep in good condition. Foreign objects in the airlock can cause damage and reduce the machine's production. Seal failure is the most common airlock assembly failure. Seal failure prevents the airlock from holding the proper pressure. Seal failure will reduce the machine's production. A machine with seal failure will have air blow out of the airlock into the hopper, reducing the amount of air exiting the machine outlet. It is recommended to visually inspect seals each week to ensure proper running condition. Replace airlock seals if a cut or tear is evident. Airlock seals should be replaced every 150 - 300 hours of operation, or once per year. Visit [www.inteccorp.com](http://www.inteccorp.com) or contact Intec for replacement instructions.

### Filter

Clean the air inlet prior to each job. If the filter gets dirty during the job, wipe clean as appropriate to ensure inlet air is moving into the system.

### Gearbox, Sprockets, and Chain

The motor and drive on the FiberForce is maintenance free. But it is important to inspect and lubricate the sprockets and chain at least once per year. Use a dry lubricant that will not attract dust and insulation.

## Troubleshooting

Problem	Likely Cause	Remedy
Machine does not turn on.	Hopper on backwards or proximity sensor not lined up with magnet	Ensure hopper opening is facing the filter side of the machine. You may need to slide the hopper slightly left or right to line of the safety sensor.
	Power cord connection is loose	Ensure appropriate power cord connection at power source.
	Power cord not connected at machine or power source.	Connect power cord.
	Machine's agitator circuit breaker(s) has tripped.	Push to reset circuit breaker(s).
	Circuit breaker at power source as tripped.	Reset circuit breaker.
	Electrical system may have a loose wire.	Have the system inspected by a qualified technician.
Blower does not run.	Check power to machine	Make sure the green and red start and stop buttons are illuminated. This shows the system is ready.
	Remote may be out of sync with the receiver.	Follow the reprogramming instruction printed on the filter panel below the sync button and sync LED. Contact Intec at 303-833-6644 for instructions on re-syncing the remote if the reprogramming instruction do not resolve the issue.
	Worn blower motor.	Have a qualified technician replace blower motor.
Agitator does not run.	Blower has to be on for agitator to come on.	Turn blower on.
	Agitator circuit breaker needs to be pressed.	Ensure agitator circuit breaker is reset.
	Foreign material causing jam in hopper.	Remove power cords, clear jam, and restart system.

	Time delay between blower and agitator may have failed.	Have a qualified technician replace the time delay relay in the system.
Machine is on, yet no material comes out of hose.	Slide gate is closed.	Open slide gate.
	Hose is plugged	Turn off machine and clear blockage from hose.
<b>Problem</b>	<b>Likely Cause</b>	<b>Remedy</b>
Machine is on, yet no material comes out of hose ( <i>continued</i> )	Air pocket in hopper is preventing insulation from feeding into agitators.	Disconnect electrical power. Redistribute insulation material inside hopper.
	Airlock seal is worn.	Inspect airlock seals for cuts and wear. Have a qualified technician replace airlock seals.
	Airlock has an obstruction preventing insulation from exiting.	Disconnect electrical power, remove obstruction.
Insulation exiting hose is dribbling out.	Heavy insulation material.	Push slide gate in 1-2 holes.
	Kink in hose.	Straighten hose.
	Airlock seal is worn.	Inspect airlock seals for cuts and wear. Have a qualified technician replace airlock seals.
Circuit breakers need resetting often.	Low voltage or low amperage.	System requires 115V / 15amp dedicated circuit.
	Extension cord gauge is too small.	Use a 12/3 heavy duty (i.e. SJ300V) extension cord with 115V.
	Chain is not aligned with sprockets.	Disconnect electrical power. Have a qualified technician realign chain and sprockets.
Machine makes a banging noise when agitator is operating.	Chain is loose.	Disconnect electrical power. Have a qualified technician adjust chain tensioner.
	Chain is not aligned with sprockets.	Disconnect electrical power. Have a qualified technician realign chain and sprockets.

## Specifications

### Weight

Standard hopper configuration

142 lbs (64.5 kg)

Tall hopper configuration

153 lbs (69.5 kg)

### Blower

Single stage 145cfm/2.8psi/4.08m<sup>3</sup>/0.193 bar

### Agitator Motor

296 in-lb torque; 81.9 rpm

### Power Requirements

One 120V – 15amp circuit

### Hose

2-1/2 inch (6.2cm) hose with quick-connect hose connections provided with system.

### Power Cord

50 foot (15.24m) 12/3 twist lock power cord provided with system.

### Dimensions



# Electrical Drawing – Electrical Panel

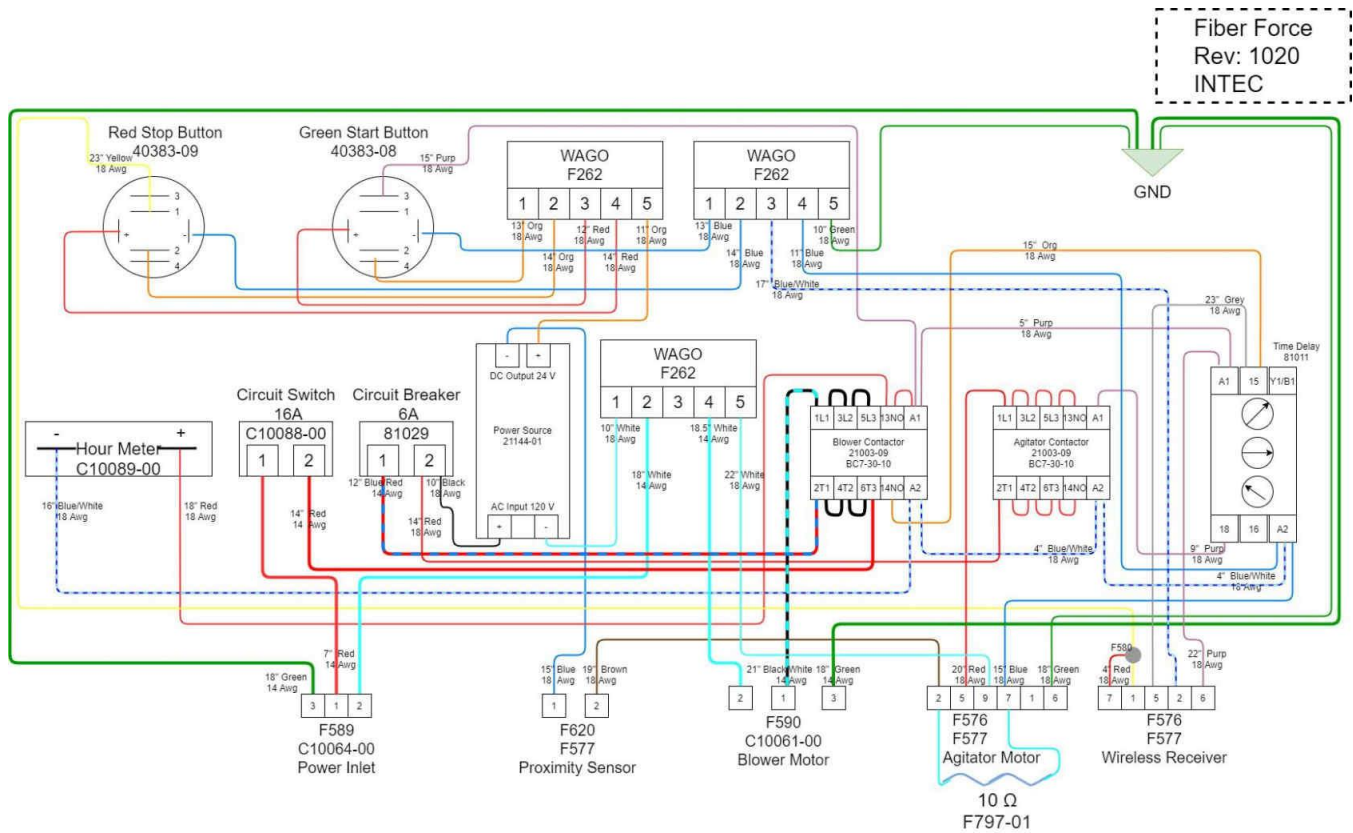

## Electrical Drawing – Wireless Controls

Fiber Force Wireless  
Rev: 1020  
INTEC

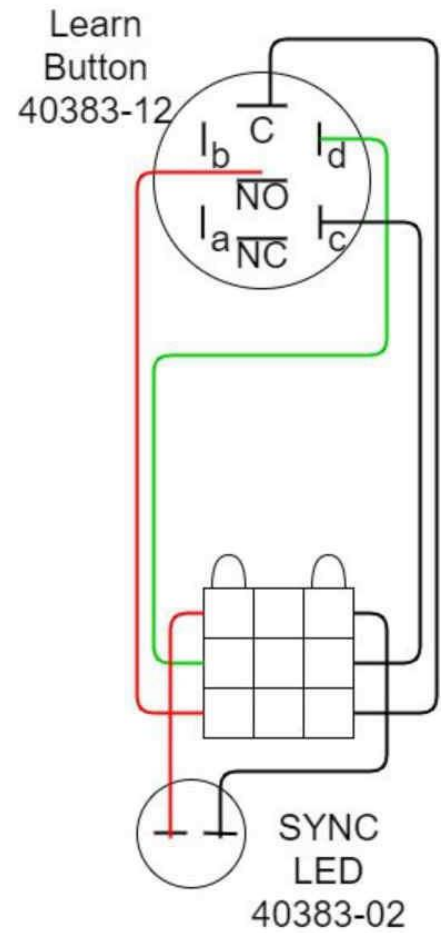
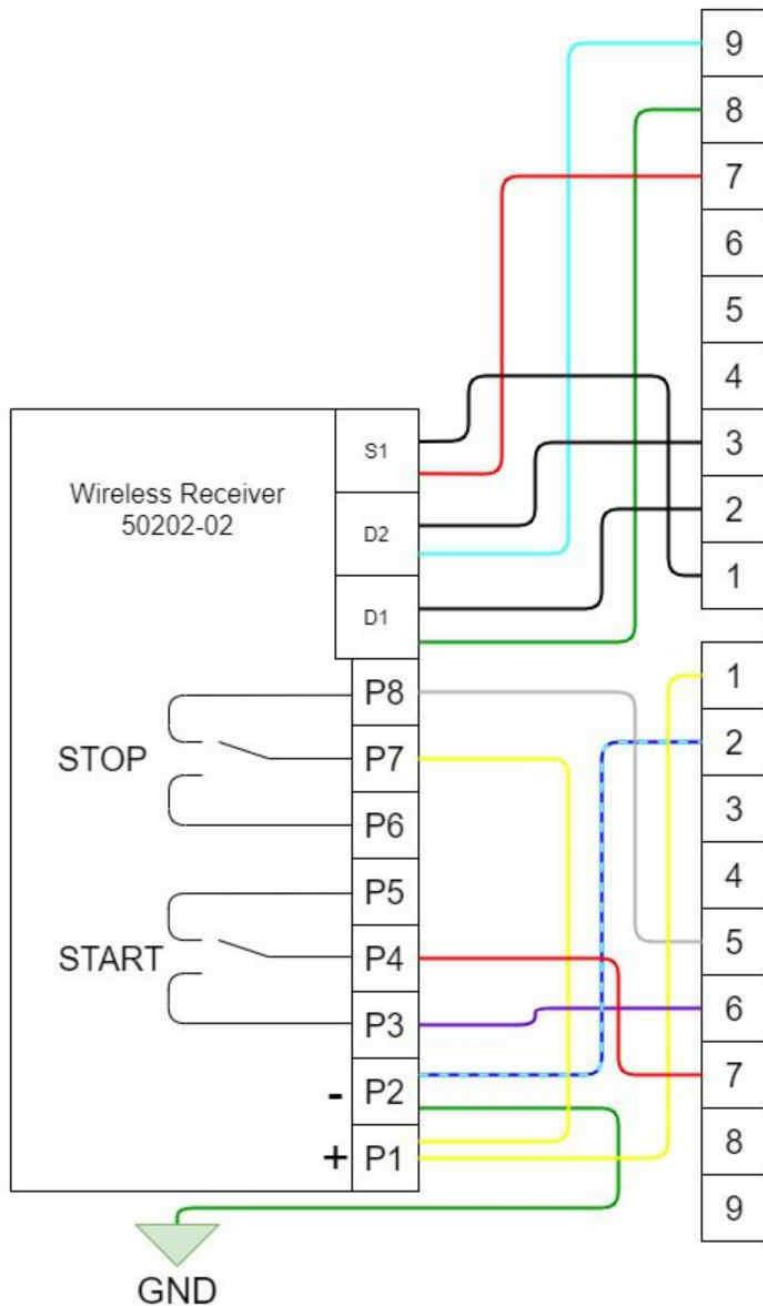

## Making a Claim for Damage or Loss

Your Intec products were carefully packed and thoroughly inspected before leaving our factory. We understand that damage to or defects with your system may unfortunately occur. Please inspect your shipment carefully upon arrival and save the shipping containers and packaging materials in case of damage.

The following table provides you with appropriate actions to take when certain issues are realized.

<b>ISSUE</b>	<b>Action to Take</b>
<p><b>1</b> <i><b>DAMAGE in Transit</b></i></p> <p>A Visible <b>PRIOR</b> to unpacking (Damage to carton or packing material).</p> <p>B Visible <b>AFTER</b> unpacking (Only apparent when unpacked).</p> <p>C Shortage (# containers does not agree to transportation bill).</p> <p>When items leave our warehouse, the shipper assumes responsibility. It is the responsibility of the consignee to file a claim. Proper documentation is necessary to support the claim. Please inspect all items properly prior to signing for them.</p>	<p>File Claim with appropriate freight carrier.</p> <p>File Claim with appropriate freight carrier.</p> <p>File Claim with appropriate freight carrier.</p>
<p><b>2</b> <i><b>Items received not correct</b></i></p> <p>A Incorrect items received.</p> <p>B Incomplete order received (not backordered).</p>	<p>Contact Intec Customer Service</p> <p>Contact Intec Customer Service <b>303.833.6644</b> <b>info@inteccorp.com</b></p>
<p><b>3</b> <i><b>Issue within the warranty period</b></i></p> <p>A Troubleshooting (machine or part not operating as intended).</p> <p>B Replacement part(s).</p> <p>Intec can assist with troubleshooting your issue, and can get you back up and running. If warranty parts are required, a return material authorization (RMA) will be issued by technical service.</p>	<p>Contact Intec Customer Service</p> <p>Contact Intec Customer Service <b>303.833.6644</b> or <b>info@inteccorp.com</b></p>
<p><b>4</b> <i><b>Issue outside of warranty period</b></i></p> <p>A Replacement part, troubleshooting.</p> <p>B Need assistance from a service center.</p>	<p>Contact Intec Customer Service</p> <p>Contact Intec Customer Service <b>303.833.6644</b></p>

Shipping Department  
Intec  
9251 Bruin Blvd  
Frederick, CO 80504

phone: 303-833-6644,  
fax: 303-833-6650  
email: info@inteccorp.com  
website: www.inteccorp.com



## Warranty

It is expressly understood and agreed that no officer, agent, salesman or employee of the manufacturer Intec (MANUFACTURER) has the authority to obligate the MANUFACTURER by any terms, stipulations, or conditions not herein expressed; that all previous representations and agreements, either verbal or written, referring to the machinery and equipment, which is the subject of this Warranty, are hereby superseded and canceled, and that there are no promises or agreements outside of the Warranty agreement. Furthermore, the MANUFACTURER hereby disclaims any implied warranties of merchantability, or implied warranties of fitness for a particular purpose.

With the above understanding, the MANUFACTURER provides the following one (1) Year Limited Warranty, and no other, for its insulation blowing machines (MACHINES):

- a) MANUFACTURER warrants to the original purchaser that the MACHINE is well made, of good material and durable; but only if the MACHINE is operated and maintained in accordance with the Instruction Manual. This Warranty is void if the MACHINE is not so operated and maintained, or if the MACHINE is used for blowing materials other than those which are intended to be used with the MACHINE.
- b) MANUFACTURER guarantees the MACHINE to be free from manufacturing defects at the time of shipment, and to remain free from defects when operated under normal use, for a period of one (1) year from the date of factory shipment, with the exception of the blowers, electrical and air lock components, which are warranted for a period of ninety (90) days from date of factory shipment.
- c) This Warranty shall not apply to any MACHINE or component part which, in the opinion of the MANUFACTURER, has been altered, subject to misuse, negligence, accident or operated beyond factory rated capacity. All requested Warranty work should be performed at MANUFACTURER's factory or by an Authorized Factory Service Facility. Failure to have the Warranty work done at MANUFACTURER'S factory or by an Authorized Factory Service Facility will void this Warranty. MANUFACTURER will bear full responsibility to repair or replace, at its option, without charge to the original purchaser, any part that, in the MANUFACTURER'S opinion, is found to be defective.
- d) All parts claimed defective by original purchaser shall be returned, properly identified, to MANUFACTURER's factory or Authorized Factory Service facility, freight prepaid. All replacement, repaired or non-defective parts will be returned to purchaser, freight collect. MANUFACTURER will supply replacement parts prior to purchaser, freight collect. MANUFACTURER will supply replacement parts prior to receipt of any parts claimed defective, only with the understanding that such replacement parts will be shipped to purchaser at the then prevailing price of said part, C.O.D., freight collect. MANUFACTURER will reimburse cost of any such part only after receipt and inspection, and finding said part defective.
- e) MANUFACTURER's liability is expressly limited to the repair or replacement of defective parts set forth in this Warranty. All other damages and warranties, statutory or otherwise, being waived are original purchaser as a condition of sale and purchase of said machines. Furthermore, the MANUFACTURER shall not be liable for damages or delays caused by defective material or workmanship.